

MANUAL

IR Handheld viewers

VIR-1300-X

VIR-1700-X

VIR-2000-X



irvi infrared viewers

CE RoHS

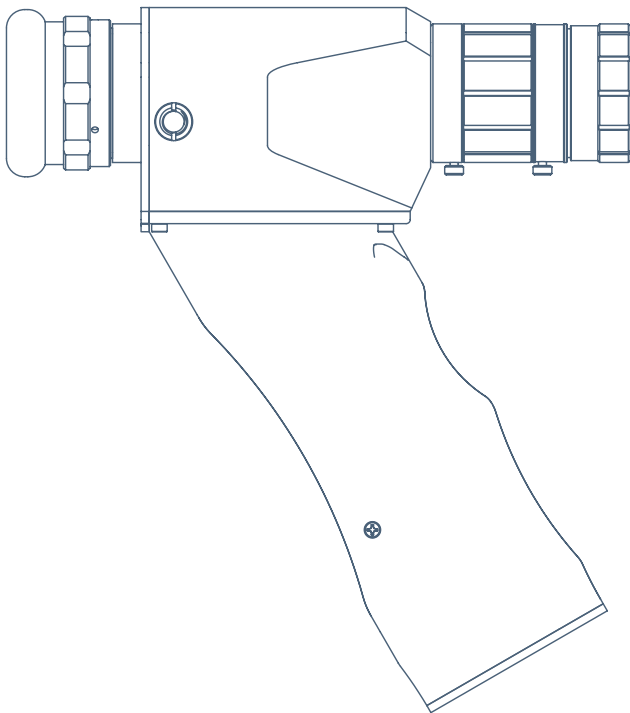

Content

Content	3
Safety requirements	4
About	4
Applications	5
How does it work?	5
Operation	6
IR viewer in comparison with a CCD camera	8
Visualization of infrared laser beam in “mid-air”	9
The Maintenance instruction	9
Black spots on screen	9
Spectral sensitivity	10
Power density	11
Photosensitivity	12
Technical information	13
Warranty	15

■ SAFETY REQUIREMENTS

- The customer is responsible for light source safety while using a viewer as a standalone device or integrated into system.
- The customer must consider protective measures if necessary.
- While assembling or operating viewer, do not stare at the direct laser (or other source) light even with safety goggles.
- This device will not protect you from direct or high light radiation. Use viewer with caution and appropriate attenuation
- Electrical safety requirements must be complied while operating this device.

■ ABOUT

High performance image conversion viewers VIR, based on high-grade image converter, are designed to observe indirect radiation of infrared laser, light emitting diodes (LED), dye and other IR-sources in 350 - 2000 nm spectral region. The lightweight, compact device can be used hand-held, post mounted with the 1/4-20 internal thread.

VIR viewer has better resolution, infrared sensitivity and factor of intensification. Also, it can be used with a CCD camera adapter for PC and video registration of the image.

This device allows viewing continuous lasers radiation as well as pulsed lasers radiation with pulse duration from ps to μ s without synchronization.

■ APPLICATIONS

- Laser alignment and safety.

IR viewers are ideal for alignment of infrared laser beam and optical components in near infrared systems.

- Semiconductors wafer inspection.

With a microscope adapter IR viewer can be used to view through the surface of silicon and gallium arsenide wafers.

- Forensics and art restoration
- Photo processing
- Thermal imaging
- Food sorting
- Vein and blood vessel observation under the skin
- Fluid inspection

■ HOW DOES IT WORK?

IR viewer is based on a first-generation high-grade image converter that has an electro-static focusing system, photocathode S-1+ with increased concentration of oxygen and screen of type P-20 with maximum of luminescence at 550nm.

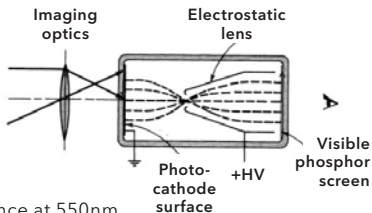

Infrared viewer focus emitted or reflected light from a chosen subject into the image tube where electron image is generated. When powered with battery the 16-18 kV voltage is generated required to accelerate the electron image into the output phosphor screen. The fluorescent green light output (550 nm) is observed via an adjustable eyepiece lens.

■ OPERATION

CAUTION! Do not use the device for direct beam viewing. Long-term over-exposure may cause satiation of screen and decrease of resolution or irreversible reduction of photocathode response.

Use your computer or phone charger with USB cable to charge the device. Do not charge the device with a charger which is more powerful than 5V DC 500mA.

1. To charge the device use USB outlet at the bottom of the handle.
2. Screw the tripod thread 1/4 inch onto the body (8) clockwise.
3. Take of the lens cover. To switch the unit on, press button (2).

NOTE: after switching off, the device continues to work some minutes due to the accumulated power.

4. Rotate the ring (3) to focus the lens 1X (F1.4/25mm). Rotate ring (3) to focus the lens 2X (F1.8/50mm). For adjustment of diaphragm (9), release the screw, adjust the diaphragm (9) and tighten the screw. Turn the ring (5) for eyepiece focus adjustment.
5. When viewing in near-infrared range, use cut-off filter (4). While viewing a reflected radiation, use metallic surface as a reflector. Any paper surface absorbs the radiation greatly.

Figure 1. VIR 1X viewer

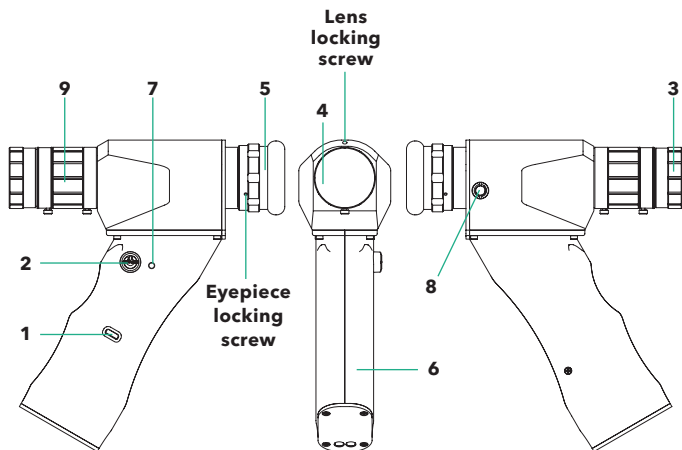

- | | |
|--------------------------|-------------------------|
| 1. USB-C for charging | 6. Handle |
| 2. Button ON/OFF | 7. LED |
| 3. Focus adjustment ring | 8. Tripod thread |
| 4. IR Filter | 9. Iris adjustment ring |
| 5. Eyepiece | |



Figure 2. Lenses F1.8/50mm (left) and F1.4/25mm (right)

■ IR VIEWER IN COMPARISON WITH A CCD CAMERA

Certain models of CCD cameras can be used to observe near-infrared radiation at wavelengths up to 1100 nm. However, because these cameras are designed for optimum performance in the visible wavelength range, as a result, they exhibit mediocre performance in the near-infrared range; image bleeding, blooming, low sensitivity and low contrast are some of the observed characteristics. Image conversion viewers are design to observe much wider spectrum.

■ VISUALIZATION OF BEAM IN “MID-AIR”

It is a misconception that an IR viewer can be used to view infrared laser beams in “mid-air” (1100 - 2000 nm). However, if dust particles are in the beam path, the beam will become partly visible. Basically, IR viewers can be used to see the projection of the infrared beam spot on a flat diffusing surface such as a white card or metallic surface.

■ THE MAINTENANCE INSTRUCTION

1. Keep away viewer from mechanical damage and moisture.
2. Protect the lenses from dirt. If necessary, clean them with clean soft cloth; remove oiled spots or deposit with cotton wool slightly wetted in rectified alcohol or with alcohol-ether mixture.
3. If necessary, unscrew the lens and clean the photocathode window, because dust can be seen through eyepiece.
4. If viewer not used please keep objective closed due to photo cathode exposure to light and possible degradation of IR sensitive material.

■ BLACK SPOTS ON SCREEN

Black spots on the screen are cosmetic blemishes in the image converter which do not affect the performance or reliability of an infrared viewers. Some spots are inherent in the manufacturing processes.

Zone	Form and size of zones on photocathode, mm	The greatest diameter of points, mm			Total area of allowable defects on screen, mm ²
		Non accounted	Accounted		
			Size	Qty	
1	Circle dia 12mm	0.1	0.5	2	0.8
2	Ring dia 12-19mm	0.25	0.8	1	0.904
3	Ring dia 19-24mm	Non specified			

Spectral sensitivity

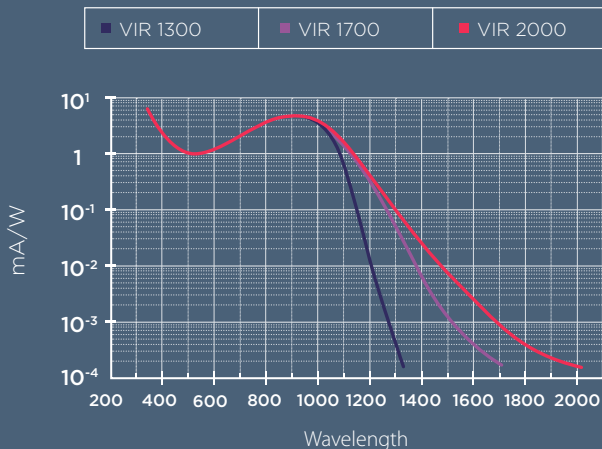

Figure 3. Spectral sensitivity (VIR series IR viewers)

■ PHOTSENSITIVITY

The minimum detectable signal for a near-infrared viewer depends on:

- Power density;
- Wavelength of incident radiation;
- Effective aperture of the objective lens;
- Distance between observed target and the viewer;
- Time duration of the signal (pulsed or continuous);
- Reflectivity of the diffusing surface;
- Sensitivity of human eye or device used in viewing the output of the IR viewer.

Approximate minimum of power densities required for observing an infrared laser source from a distance of one meter:

- $20 \mu\text{W}/\text{cm}^2$ for a 1060 nm; $500 \mu\text{W}/\text{cm}^2$ for a 1300 nm.

The IR viewer with sensitivity 350-2000 nm has the photocathode S-1+ type which contain the increased concentration of oxygen. It increases sensitivity of the photocathode. IR viewer can be used to view 2.0 μm laser beam at minimum power density $2 \text{ W}/\text{cm}^2$. When operated in the 1500-2000 nm range, IR viewer has a low spectral response, therefore observations can be performed when the following requirements are met:

1. Use an IR cut-off filter or interference filter and darken the room to reduce external background;
2. Use a metallic surface for observation reflected radiation, as any other material might absorb infrared radiation.

Technical information

Version	1 (1X)	2 (2X)
Spectral sensitivity	<ul style="list-style-type: none"> ■ VIR-1300-x (350-1300nm) ■ VIR-1700-x (350-1700nm) ■ VIR-2000-x (350-2000nm) 	
Resolution (center)	60 Lp/mm	60 Lp/mm
Field of view	40°	20°
Magnification	1X	2X
Objective lens	F1.4/25mm	F1.8/50mm
Adjustable iris	Included	Included
Focus	0.1m to ∞	0.5m (0.15m)* to ∞
Distortion of image	20%	
Cell battery	200 mAh 3.7V Li-Po	
Battery life fully charged	Up to 60 hours	
Weight without objective lens	0.316 kg	
Dimensions	153x173x51 mm	
Temperature range	-10°C...40°C	
Tripod or handle	R1/4"	

* with macro ring

Lenses 1X (F1.4/25mm) and 2X (F1.8/50mm) are exchangeable.

Standard kit for version 1X includes:

- IR viewer;
- lens 1X;
- IR filter;
- 5V 1A charger;
- case.

Standard kit for version 2X includes:

- IR viewer;
- lens 2X;
- macro ring;
- IR filter;
- 5V 1A charger;
- case.

Accessories available upon request:

- Neutral density filter for lens 1X(0.5% @ 1064nm)
- Neutral density filter for lens 2X(0.5% @ 1064nm)
- Microscope adapter
- 1:1 Optical relay lens adapter for c-mount camera
- Video adapter VA-1
- Lens 1X(F1.4/25mm)
- Macro ring
- C-mount ring for any C-mount type lenses
- Tripod
- Lens 2X (F1.8/50mm)

■ WARRANTY

Infrared viewing device VIR meets specifications of the manufacturer and declared operation.

The warranty period of the device is 24 months from the date it was sold to the consumer.

Claims not accepted, and warranty repair are not made, because of the improper use or incorrect service and maintenance of product instructions.

The company shall not accept warranty claim:

- non-authorized alteration,
- disassembling of device,
- mechanical or any external damages,
- if 2 years warranty term has expired.

SERIAL NO.

VERSION NO.

SPECTRAL RANGE

DATE OF INVOICE

irvi | infrared viewers



ADOS-TECH, UAB
Mokslininku st. 6B,
LT-08412, Vilnius, Lithuania
Phone: +370 5 270 6407
Fax: +370 5 210 0067
sales@ir-viewers.com
www.ir-viewers.com

ADOS-TECH
ADVANCED DIGITAL OPTICAL SYSTEMS



OPTO SCIENCE

株式会社オプトサイエンス WEB www.optoscience.com
TEL 03-3356-1064 E-mail info@optoscience.com