



OZ Optics

shop.ozoptics.com
www.ozoptics.com

219 Westbrook Road
Ottawa, ON, Canada, K0A 1L0

Toll free: 1-800-361-5415
Telephone: 1-613-831-0981
Fax: 1-613-836-5089
sales@ozoptics.com

LOW COST SMART DETECTOR HEAD/OPTICAL POWER MONITOR

Features

- Low cost
- Slim and compact size
- Built-in InGaAs detector for IR range or Si detector for Visible
- Interchangeable optical receptacles available
- Calibrated and uncalibrated versions available
- Customer may perform their own calibration
- USB and RS232 interfaces

Applications

- Long term Remote Power Monitoring
- Fiber optic assembling and testing
- Optical Test Systems
- Passive optical components burn-in stations
- General optical power measurements
- Embedded systems

Product Description

The new Low Cost Smart Detector Head/Optical Power Monitors offer OEM modules (with no built-in display) that can be embedded in systems for remote power monitoring or for long term power logging for Burn-in Test Stations. The OEM version comes with a USB interface in the LSDH, and with RS232 in the POM-600 (rectangular base). SPI or I2C remote interfaces can be provided on demand for volume OEM orders. Customers can install OZ Optics' provided User Graphical Interface on a host PC to display the measured optical power. Or customers can use the device commands to develop their own User Graphical Interface.

The Low Cost Smart Detector Head/Optical Power Monitor offers a high, greater than 60 dB linear dynamic range and can be easily embedded in long term power monitoring stations like Environmental Optical Test Systems or long term burn-in stations.

The device can be offered with calibration at discrete wavelengths, or with no wavelength calibration for relative power measurements. Customers may also perform their own calibration.

OZ Optics also offers equivalent units with built-in displays. The POM-500 product datasheet can be accessed at the following link: https://www.ozoptics.com/ALLNEW_PDF/DTS0150.pdf



Low Cost Smart Detector Head (LSDH)



Optical Power Monitor (POM-600)

Ordering Information For Standard Parts

Bar Code	Part Number	Description
62514	LSDH-IR-C	OEM Low cost detector head/Optical Power Monitor (Round housing) with 1 mm active area InGaAs detector, for 900–1650 nm, -50 dBm to +10 dBm dynamic range. With USB remote interface. Unit comes calibrated at 1064 nm, 1310 nm, 1480 nm, 1550 nm and 1625 nm. Unit supplied with FC, LC, ST and SC removable receptacles.
62513	LSDH-VIS-C	OEM Low cost detector head/Optical Power Monitor (Round housing) with 1 mm active area Si detector, for 450–1000 nm, -50 dBm to +10 dBm dynamic range. With USB remote interface. Unit comes calibrated at 520 nm, 635 nm, 780 nm, 850 nm and 980 nm. Unit supplied with FC, LC, ST and SC removable receptacles.
63997	POM-600-IR-C	OEM Low cost detector head/Optical Power Monitor (rectangular housing) with 1 mm active area InGaAs detector, for 900–1650 nm, -65 dBm to +10 dBm dynamic range. With RS232 remote interface. Unit comes calibrated at 1064 nm, 1310 nm, 1480 nm, 1550 nm and 1625 nm. Unit supplied with FC, LC, ST and SC removable receptacles.
63994	POM-600-VIS-C	OEM Low cost detector head/Optical Power Monitor (rectangular housing) with 1 mm active area Si detector, for 450–1000 nm, -65 dBm to +10 dBm dynamic range. With RS232 remote interface. Unit comes calibrated at 520 nm, 635 nm, 780 nm, 850 nm and 980 nm. Unit supplied with FC, LC, ST and SC removable receptacles.
64016	POM-500-R-3	Interchangeable FC receptacle for POM-500, POM-600, and LSDH Optical Power Meters. Compatible with flat, super, ultra and angled FC connectors.
64018	POM-500-R-SC	Interchangeable SC receptacle for POM-500, POM-600, and LSDH Optical Power Meters. Compatible with super, ultra and angled SC connectors.
64019	POM-500-R-LC	Interchangeable LC receptacle for POM-500, POM-600, and LSDH Optical Power Meters. Compatible with super, ultra and angled LC connectors.
64017	POM-500-R-8	Interchangeable ST receptacle for POM-500, POM-600, and LSDH Optical Power Meters.

Standard Product Specifications

		LSDH	POM-600
Measurement range ¹	IR	-50 to +10 dBm	-65 to +10 dBm
	VIS		
Wavelength range		900 to 1650 nm with IR detector. 450 to 1000 nm with visible detector.	
Calibrated wavelengths	IR	1064, 1310, 1480, 1550, and 1625 nm	
	VIS	520, 635, 780, 850, and 980 nm	
Resolution		0.01 dB	
Accuracy ²		± 5% (+0 to -50 dBm) at calibrated wavelengths using singlemode fiber and FC/PC receptacle.	
Linearity ³		± 0.05 dB (+0 to -50 dBm)	
Measurement units		pW, nW, μW, mW, W, dBm, dB, REL	
Available optical receptacles		FC; AT&T-ST; SC and LC	
Sampling rate		Typical 1000 Hz	
Dimensions (L x W x H) (not including receptacle)		41.7 x 40.7 x 40.7 mm	96 x 54 x 19.2 mm
Weight		74 g	122 g
Communications interface		USB	RS232
Power supply		5 VDC via USB	4 to 8 VDC
Temperature range, non-condensing	Operating	0 to +50 °C	
	Storage	-40 to +70 °C	

Notes: ¹ Maximum measurement range is dependent on the responsivity of the detector, which is related to the wavelength, and the area of the detector that is illuminated by the incoming light. Please consult OZ Optics for high power measurement.

² Measured at 23 °C.

³ Measured at 23 °C, using SM fiber terminated with FC connector at 1550 nm and 850 nm for respectively IR and Visible power meter.

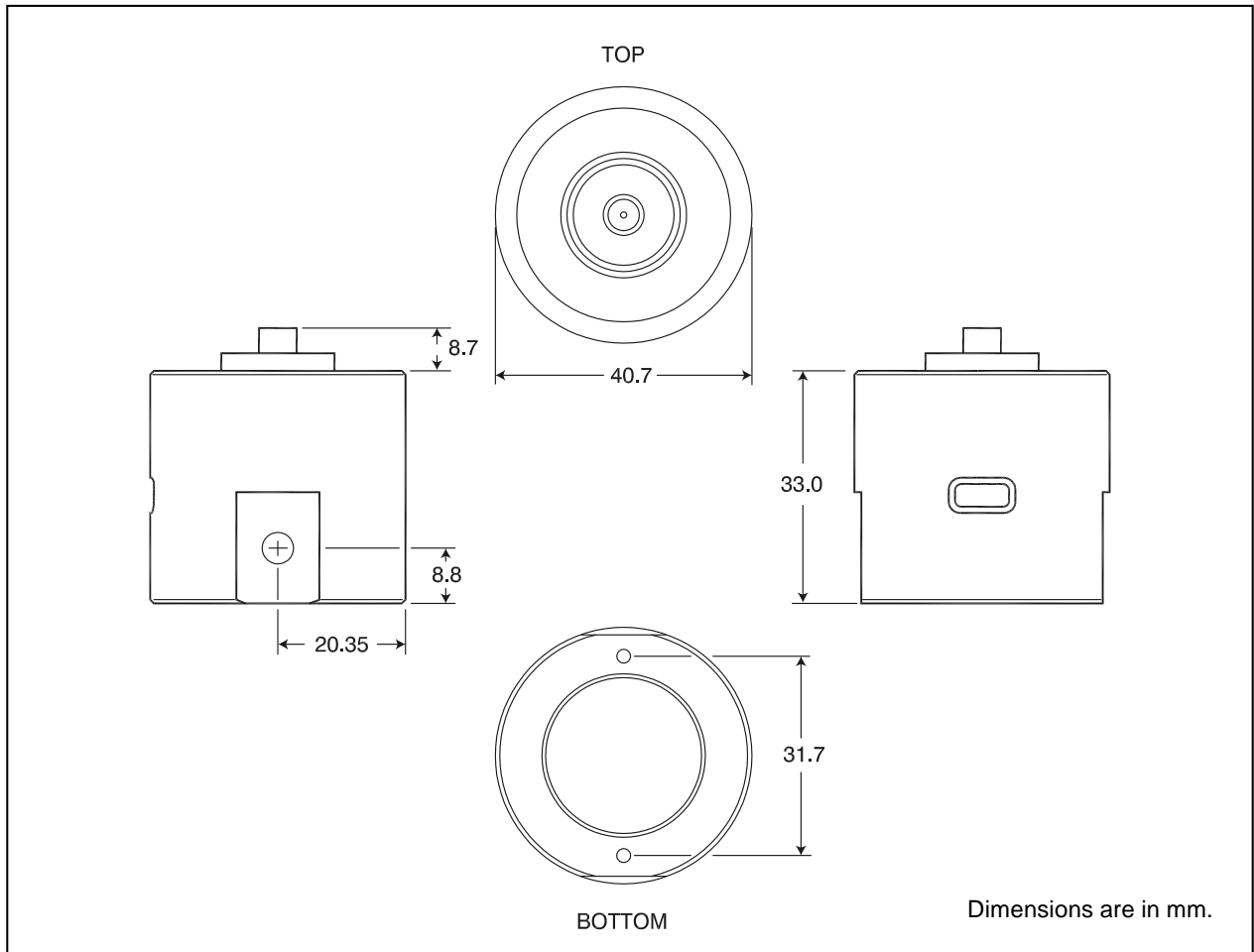

Figure 1. Low Cost Smart Detector Head (LSDH)

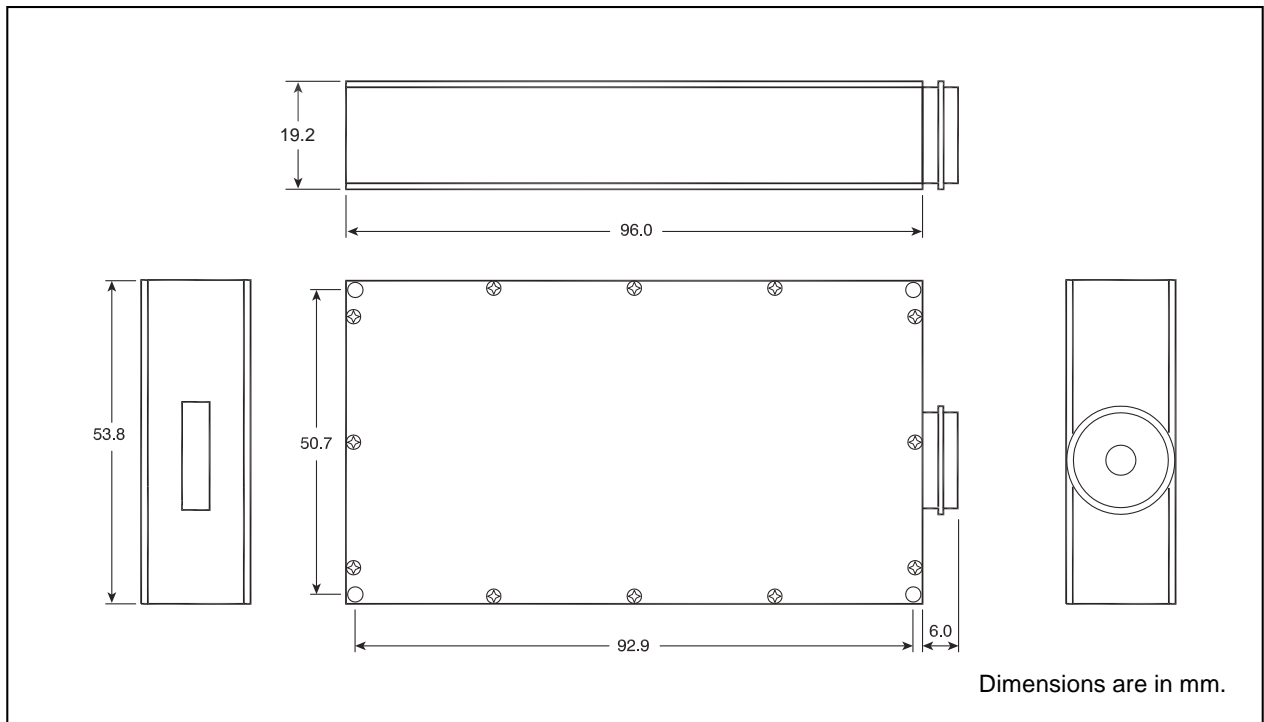

Figure 2. Optical Power Monitor (POM-600)

Ordering Example For Standard Parts

A customer needs to set up a 4-channel long term power monitoring system to measure power stability of his pigtailed 1550 nm laser diodes terminated with FC/APC connectors. The customer wants to remotely control the units through a USB hub. All he needs to order is the following part:

Bar Code	Part Number	Description
62514	LSDH-IR-C	OEM Low cost detector head/Optical Power Monitor (Round housing) with 1 mm active area InGaAs detector, for 900–1650 nm, -50 dBm to +10 dBm dynamic range. With USB remote interface. Unit comes calibrated at 1064 nm, 1310 nm, 1480 nm, 1550 nm and 1625 nm. Unit supplied with FC, LC, ST and SC removable receptacles.

Questionnaire

1. What is your operating wavelength range?
2. What is the maximum power level that you need to measure?
3. What is the minimum power level that you need to measure?
4. What type of optical receptacle do you need?
5. Do you need to be able to control the power meter from a computer?
6. Do you want a unit with built-in or without display?

Ordering Information For Custom Parts

Cylindrical Head with USB interface

Description

Detector Head

Part Number

LSDH-W-C

C: C = Calibrated at discrete wavelengths
N = Non-calibrated

W: Detector range:
IR = infrared, 900 to 1650 nm
VIS = visible, 450 to 1000 nm

Rectangular Head with RS232 interface

Description

Detector Head

Part Number

POM-600-W-C

C: C = Calibrated at discrete wavelengths
N = Non-calibrated

W: Detector range:
IR = infrared, 900 to 1650 nm
VIS = visible, 450 to 1000 nm

Optical Receptacle*

Description

Optical receptacle

Part Number

POM-500-R-X

X: Receptacle style:
3 = FC flat or angled
8 = AT&T-ST
SC = SC
LC = LC

* The same receptacles are used for the POM-500, POM-600, and LSDH. The receptacles are offered as a kit for low-quantity orders. Individual receptacles are offered only for volume OEM demands (>100 pcs.)

Ordering Example For Custom Parts

An OEM customer wants to perform his own calibration and stack several non-calibrated rectangular power monitor heads to log optical power continuously at 1550 nm. His devices under test are each terminated with an LC connector on the end of a fiber. He wants to use RS232 for communication. He can do this by ordering the following parts:

Bar Code	Part Number	Description
62510	POM-600-IR-N	OEM Low cost detector head/Optical Power Monitor (rectangular housing) with 1 mm active area InGaAs detector, for 900–1650 nm, 70 dB dynamic range. With RS232 remote interface. Unit comes non-calibrated. With no receptacle included.
64019	POM-500-R-LC	Interchangeable LC receptacle for POM-500, POM-600, and LSDH Optical Power Meters. Compatible with flat, super, ultra and angled LC connectors.

Frequently Asked Questions (FAQs)

Q: Can I use the OEM version in my remote system?

A: Yes. The OEM power meter is well suited to being integrated on customer systems. The customer can add his own calibration table over the factory calibration table.

Q: Can I order a unit with only one optical receptacle?

A: For low quantity orders, the meter comes by default with a receptacle kit with: FC/ST/LC/SC. For volume OEM orders, units can be provided with a required receptacle only.

Q: Can I order a unit with built-in display and with a built-in battery?

A: Yes, we do offer equivalent Pocket style power meters with display and built-in rechargeable battery. The product datasheet can be accessed at the following link: https://www.ozoptics.com/ALLNEW_PDF/DTS0150.pdf

Q: What is the recommended calibration period?

A: For the calibrated version, we do recommend calibration of the meter every 24 months.