



OZ Optics

shop.ozoptics.com
www.ozoptics.com

219 Westbrook Road
Ottawa, ON, Canada, K0A 1L0

Toll free: 1-800-361-5415
Telephone: 1-613-831-0981
Fax: 1-613-836-5089
sales@ozoptics.com

MODULATOR BIAS CONTROLLER - CHIP SIZE SINGLE FUNCTION

PRELIMINARY

Features

- Single-function unit with Q+/Q-, Null/Peak options
- Low profile (1.8" x 0.8" x 0.5")
- Access for external photo-detector

Product Description

The Chip size MBC is a single-function chip-size OEM version of the Modulator Bias Controller (MBC) family. It is designed especially for digital system applications. The small size of the board makes it easy to be integrated into the system. Chip size MBC is designed to lock the working point of the modulator at positive slope quadrature (quad+), negative slope quadrature (quad-), null or peak points of its characteristic curve respectively. The locking mode and slope has to be specified before ordering. The Chip size MBC is designed to use the built-in PD of the modulator but the user may also use an external PD by soldering it to the MBC-Chip.

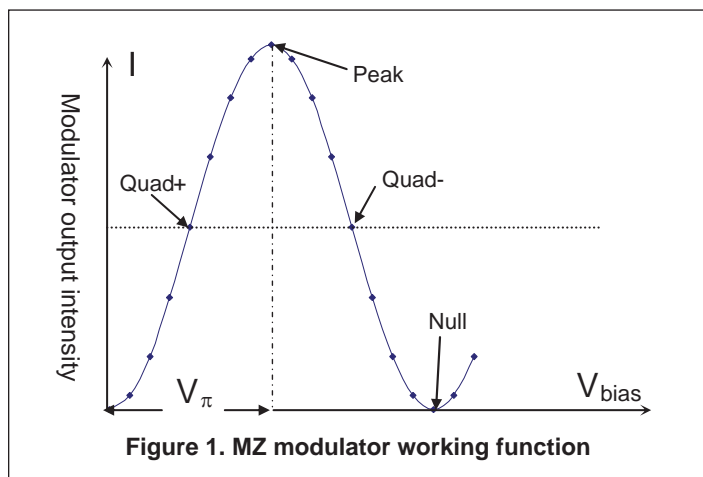
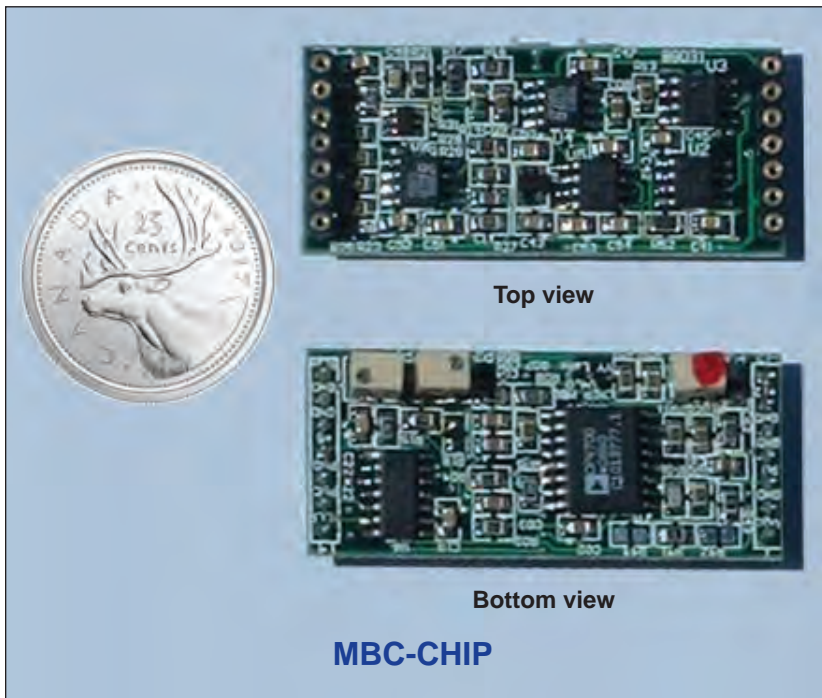

Specifications

Parameters	Min.	Typ.	Max.
Input Signal Current (μA)	0.8		80
Locking Accuracy (Degree)		1	3
DC Bias Voltage (V)	-10		+10
Pilot Tone Frequency (kHz)		9.8	
Pilot Tone Amplitude Range ¹ (mV)	0–300		
VC DC Voltage (V)	-10		+10
Positive Power Supply (V)	10	12	+15

Parameters	Min.	Typ.	Max.
Negative Power Supply (V)	-10	-12	-15
Positive Supply Current (mA)			20
Negative Supply Current (mA)			20
Operating Temperature ($^{\circ}\text{C}$)	0–70		
Storage Temperature ($^{\circ}\text{C}$)	-40–80		
Dimension L x W x H (inch)	1.8 x 0.8 x 0.5		

¹ Manually adjustable.

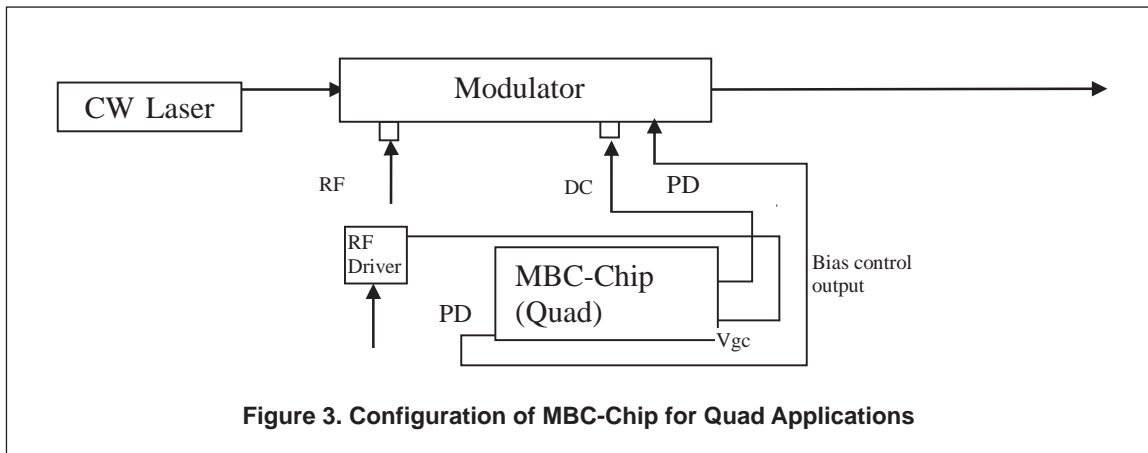
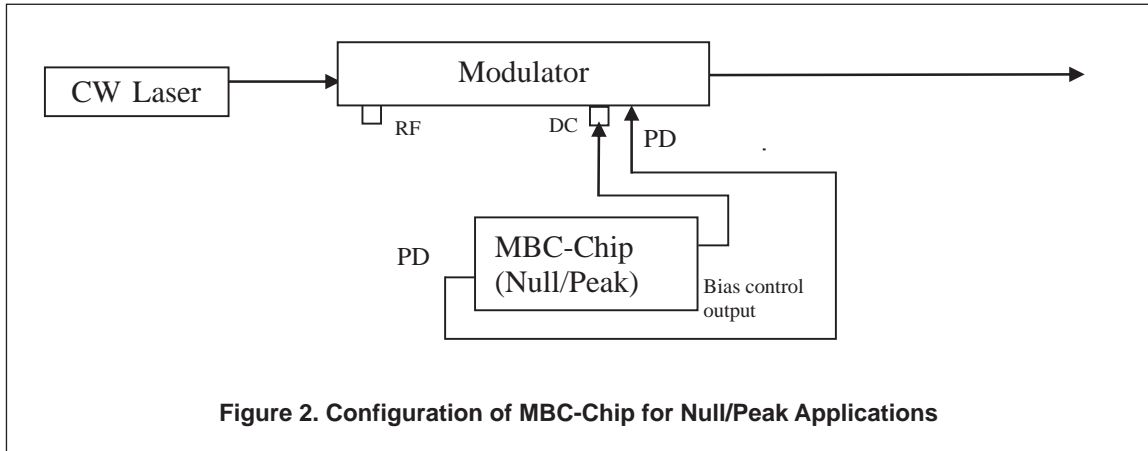

Part Number

MBC-CHIP-PP-X-L

PP = Pigtailed Photodiode code:
 PD = Pigtailed photodiode included
 00 = Pigtailed photodiode not included
 Leave connector code blank

L = Locking point:
 N = Null
 P = Peak
 QN = Quad-
 QP = Quad+

X = Connector code:
 3U = FC/UPC
 3A = FC/APC
 SCU = SC/UPC
 SCA = SC/APC
 LCU = LC/UPC
 LCA = LC/APC